

Cable Ties

Extra Wide Range

• Options:	Natural or Black.
• Material:	Nylon 66.
• Temperatures:	Operating Temperature: -40°C to +85°C Tightening Temperature: -10°C to +60°C Max. Admissible Point: +110°C (For Short Time) Fusion Temperature: +256°C
• Limit Oxygen Index (LOI):	27%
• Flammability Rating:	UL 94 Class V2
• Dielectric Strength:	50,000 Volts/mm
• Weather Resistance:	High resistance to bases, oils, greases, oil derivatives, chloride solvents; limited resistance to acids; not resistant to phenols; halogen-free resins.
• Comply With:	EN IEC62275:2019, IEC 62321-5: 2013, IEC 62321-4: 2013+ AMD1: 2017, EC 62321-7-2: 2017, IEC 62321-6: 2015, IEC 62321-8: 2017
• UL Approved:	E474504
• Characteristics:	<ul style="list-style-type: none"> • Beal UK Cable Ties are produced in UL Approved Nylon 6.6 giving excellent flexibility and mechanical strength. • The Black Cable Ties have added Carbon Black enabling them to be UV Stable and suitable for Outdoor Use and giving excellent resistance to weathering and ageing. • High tensile strength with low insertion force.
• Example Applications:	Electrical installations, Industrial Wiring, Automotive, Panel building.

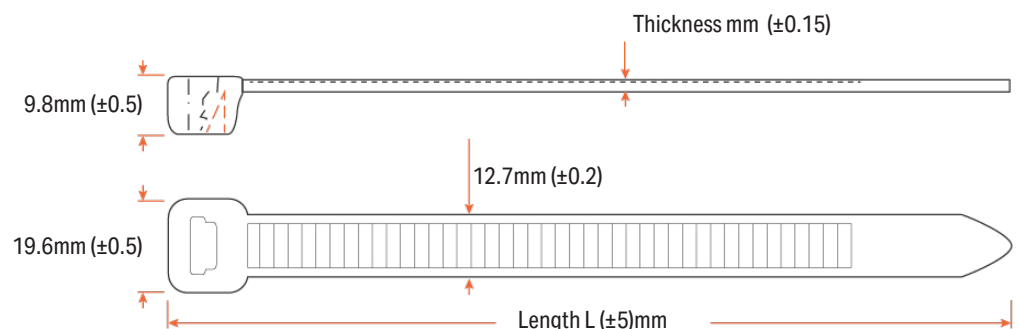
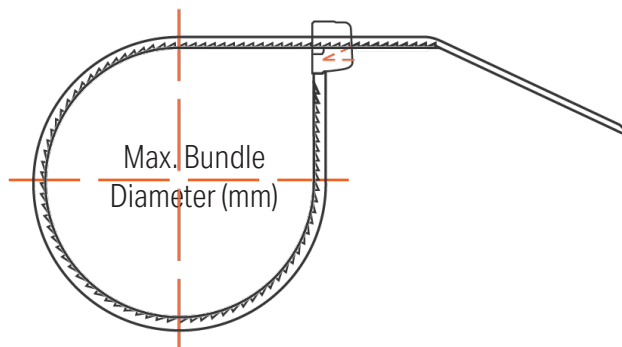

Cable Ties

Extra Wide Range

Item No.	Colour	Width W (mm)	Thickness (mm)	Length L (mm)	Max. Bundle Diameter (mm)	Min. Tensile Strength (kg)
TR43-B	Black	12.7	2.2	280	73	114
TR44-B	Black	12.7	2.2	380	105	114
TR39-B	Black	12.7	2.2	480	137	114
TR13-B	Black	12.7	2.2	580	169	114
TR28-B	Black	12.7	2.2	730	216	114
TR45-B	Black	12.7	2.2	880	264	114
TR18-B	Black	12.7	2.2	1030	312	114
TR52-B	Black	12.7	2.2	1530	470	114
TR43-W	Natural	12.7	2.2	280	73	114
TR44-W	Natural	12.7	2.2	380	105	114
TR39-W	Natural	12.7	2.2	480	137	114
TR13-W	Natural	12.7	2.2	580	169	114
TR28-W	Natural	12.7	2.2	730	216	114
TR45-W	Natural	12.7	2.2	880	264	114
TR18-W	Natural	12.7	2.2	1030	312	114
TR52-W	Natural	12.7	2.2	1530	470	114

STORAGE AND USAGE OF NYLON CABLE TIES

BEAL UK cable ties are made from high quality Nylon 66 resin. Moisture absorption is an essential factor for this material to retain its strength and maintain optimal performance. To this end, it is important for the cable ties to be kept in a sealed package wherever possible.

Below are some helpful storage suggestions:

1. The ideal storage temperature is around 23°C with the humidity over 50%.
2. Do not open the bag before use. Please try to finish the whole package of cable ties shortly after opening or reseal the bag until you are ready to use again.
3. Do not expose directly under sunlight (except UV weather resistant cable ties).
4. Avoid storing cable ties close to warm objects (such as heaters).